

THREE 20" PLASTIC RISERS STANDARD (LARGER AVAILABLE)

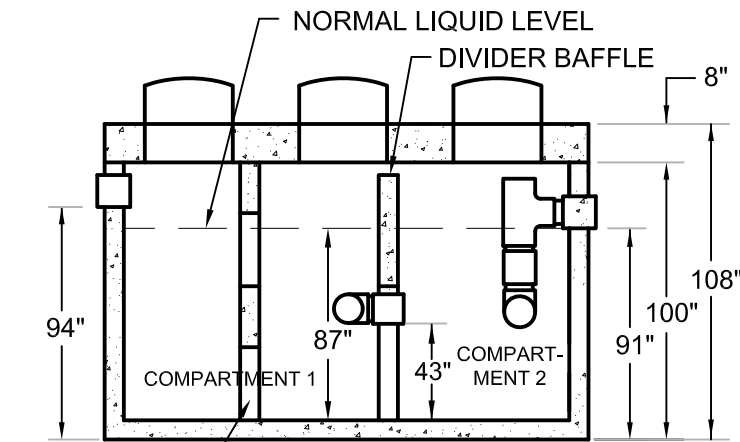

SECTION A-A  
STIFFENING WALL

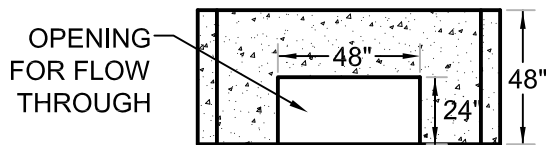

SECTION B-B  
STIFFENING WALL  
(IN BASE & EXTENSION SECTIONS)

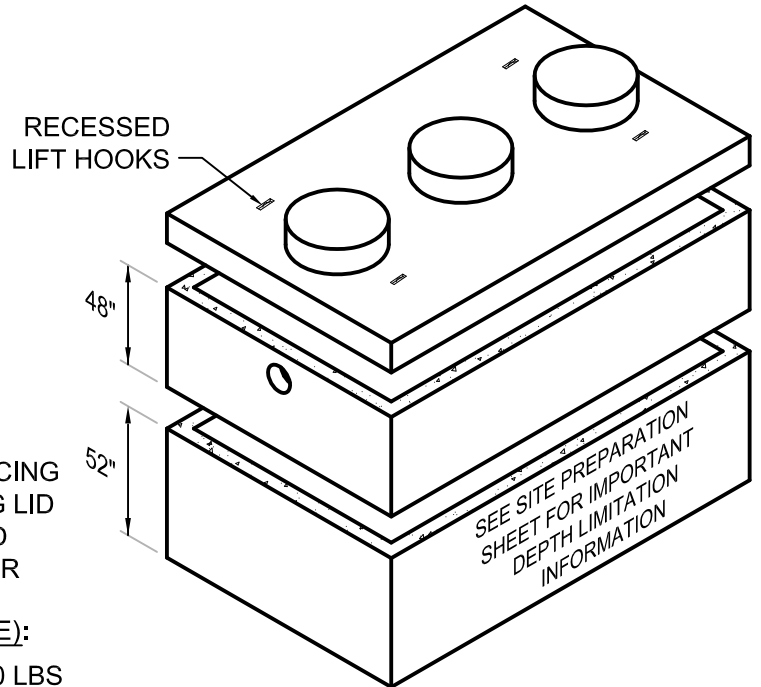

**STANDARD FEATURES:**

- 4500 PSI CONCRETE
- GRADE 60 REINFORCING
- 8" TRAFFIC BEARING LID
- AASHTO H-20 RATED
- 4" WALLS AND FLOOR

**WEIGHT (APPROXIMATE):**

TANK	19,170 LBS
48" EXTENSION	12,264 LBS
8" LID	12,650 LBS
<b>TOTAL</b>	<b>43,085 LBS</b>

**NOTES:**

- GROUND WATER LEVEL MUST BE 6 FT OR MORE BELOW GRADE
- STANDARD INLET/OUTLET FITTINGS ARE 4" RUBBER BOOTS (6" AVAILABLE)
- BUTYL SEALANT APPLIED BETWEEN JOINTS
- **MAXIMUM BURY DEPTH TO BOTTOM OF TANK**  
AASHTO H-20 LOADING: 11 FT  
NON TRAFFIC (SOIL) LOADING: 13 FT

**6000 GALLON SEPTIC TANK**



PO Box 357  
Kyle, Texas 78640  
512.268.9711  
Austin Line 512.476.5838  
Fax 512.268.0215  
hillcountryconcrete.com